



KENNEDY TOWNSHIP  
APPLICATION FOR STREET OPENING



APPLICATION NO. \_\_\_\_\_

APPLICANT \_\_\_\_\_

ADDRESS \_\_\_\_\_

CITY \_\_\_\_\_ STATE \_\_\_\_\_ ZIP CODE \_\_\_\_\_

TELEPHONE NO. \_\_\_\_\_ FAX NO. \_\_\_\_\_

EMERGENCY CONTACT \_\_\_\_\_ TELEPHONE NO. \_\_\_\_\_

PURPOSE OF STREET OPENING \_\_\_\_\_

LOCATION OF OPENING \_\_\_\_\_

(ATTACH DRAWING OR MAP)

NEAREST INTERSECTION TO OPENING \_\_\_\_\_

SIZE (IN SQUARE FEET) OF STREET/SIDEWALK TO BE OPENED: \_\_\_\_\_

DISTANCE OF OPENING (IN FEET) FROM CURB OR PAVEMENT EDGE \_\_\_\_\_

FEES AS PER ORDINANCE NO. 427 \_\_\_\_\_

DATES OF OPENING \_\_\_\_\_

DATE OPENING IS TO BE REFILLED AND TEMPORARILY RESURFACED (TEMPORARY SURFACE TO BE MAINTAINED FOR A MINIMUM OF TWO (2) WEEKS FREE OF DEPRESSIONS) \_\_\_\_\_

PUBLIC LIABILITY INSURANCE (MINIMUM OF \$1,000,000.00) \_\_\_\_\_

PROPERTY DAMAGE (MINIMUM OF \$100,000.00) \_\_\_\_\_

DEPOSIT OR BOND (MINIMUM OF \$500.00) \_\_\_\_\_  
(AMOUNT TO BE ESTABLISHED BY KENNEDY TOWNSHIP)

The Applicant agrees to perform all work in accordance with Ordinance Nos. 321 and 427, all Kennedy Township Regulations, Federal Laws, instructions and directions of the Township of Kennedy Engineer. The Applicant agrees to assume all liability in connections with the work described herein.

The Applicant acknowledges and understands that the street/sidewalk opening will be restored with construction material the same as original and to the satisfaction of the Kennedy Township Engineer and further agrees to be bound by the provisions of the ordinances, specifications and regulations of the Township governing openings in or under municipal streets and to such special conditions, restrictions and regulations as imposed by the Director.

\_\_\_\_\_  
APPLICANT

\_\_\_\_\_  
DATE

TOWNSHIP OF KENNEDY  
ALLEGHENY COUNTY, PENNSYLVANIA  
ORDINANCE NO. 321

An ordinance of the Township of Kennedy, Allegheny County, Pennsylvania, to regulate ground opening of streets and right-of-ways for the use of the public and repealing ordinances No. 21 of 1958, No. 223 of 1985 and No. 300 of 1992.

BE IT ORDAINED AND ENACTED by the Township Commissioners of the Township of Kennedy, Allegheny County, Pennsylvania and is hereby ordained and enacted by the authority of same.

SECTION 1 - The opening of the surface of any street or right-of-way dedicated for public use of the Township of Kennedy is hereby prohibited unless a permit is obtained for that purpose in the manner hereinafter described. Such permit shall be issued by the Building Inspector of said Township.

SECTION 2 - Permits for the opening of any street or right-of-way shall only be issued upon compliance with the following provisions:

- (A) Kennedy Township shall require a Maintenance Bond for one year from date of completion of the proper restoration of the surface affected as follows:
- (1) For an opening of up to 300 square feet, a bond of \$2,000.00 shall be required.
  - (2) For an opening of more than 300 square feet, the value of the bond shall be determined by the Township Engineer.
  - (3) For utility companies - gas, water and electrical - a maintenance bond is not required.
- (B) Written application, upon form supplied by Township, shall be filed for each and every opening and filed by the person, firm or duly authorized agent of a corporation desiring such permit; the application shall set forth the purpose of opening, extent, size and location of the same; date or dates during which such opening is to be permitted, the date and time such opening is to be refilled and temporarily resurfaced in the manner hereinafter provided and shall provide applicant will faithfully comply with every provision of this Ordinance; all applications for permits shall be accompanied by a plan or sketch showing the location, character and dimensions of the

proposed opening for the installation of the new work or the location and character of the alteration involving changes in the location of pipes, conduits, wires or structures incidental thereto.

- (C) No permits shall be granted in any case until the applicant shall have executed and delivered to the Township a hold harmless commitment by which the owners of said property for which openings are permitted agree to obligate themselves and indemnify and save harmless the Township from any loss, damage or expense whatsoever, in any manner occasioned by or arising from the opening of any street or right-of-way or the work done in consequence thereof, or the manner of doing such work; and to further agree to amicable entry of judgement or lien for all damages and costs sustained by reason of breach of such agreement to indemnify.
- (D) Prior to the issuing of such permit, every such applicant shall pay to the Township of Kennedy the monies hereinafter required for the purpose hereinafter provided.
- (E) No permit shall be granted to any applicant unless such applicant shall have first paid to the Township any and all money which may be due to the Township for prior openings made or any loss, damage or expense in any manner occasioned by or from openings of streets or ways in said Township.

SECTION 3 - The basis of improvement of street and surface openings shall be the actual number of square feet of paving or resurfacing necessary to completely repair the street surface at such opening. All openings shall be measured by the Township Engineer and such measurement shall be final and conclusive.

SECTION 4 - All work done under the authority of any permit shall be inspected by the Township Engineer and/or an authorized inspector; such inspection shall be done at the sole expense of the applicant.

*Amended by Ordinance 427*

SECTION 5 - Each and every applicant shall pay to the Township the following permit fees at the time application is made for a permit to excavate or open any street or right-of-way in the Township.

Where the excavation or opening is:

- |  |          |
|--|----------|
| a. Less than 100 sq ft   | \$ 75.00 |
| b. 100 sq ft but less than 200 sq ft                               | \$150.00 |
| c. 200 sq ft but less than 300 sq ft                               | \$225.00 |
| d. 300 sq ft but less than 1,000 sq ft                             | \$555.00 |
| e. Each additional 300 sq ft or part thereof will be an additional | \$225.00 |

SECTION 6 - The contractor or person doing the work of opening or excavating as aforesaid shall, at all times, maintain in his possession and shall exhibit to any official of said Township upon demand the permit to do the said work, which permit only shall be evidence of authority for the doing of the same.

SECTION 7 - All openings shall be refilled and temporarily resurfaced on or before the time fixed in the permit. Final repairs according to the following:

- (a) Attached herein are typical repair details of paved streets or roadway openings. Also, trench pipe zone details for applicable pipe used. See SD-1 to SD-4.
- (b) Only one-half of the roadway shall be disturbed at any time; the other half shall remain intact until the first half is satisfactory for maintenance of traffic unless other arrangements are perfected to temporarily bridge the trench while the surface and base course, if any, are being placed and cured, providing curing is necessary. One-way traffic must be satisfactorily maintained at all times.
- (c) Traffic accommodation and control - this work is the maintenance and protection of traffic adjacent to and within the construction area. As per Section 900 Form 408, Commonwealth of Pennsylvania, Department of

Transportation, or as deemed necessary by Township or the Building Inspector.

(d) Written notice shall be given when the work is completed.

SECTION 8 - The Township Engineer or Building Inspector shall have the right to inspect all work done under street opening permits and shall see that all the terms and provisions of this Ordinance are enforced and they shall have the power to prosecute every person, firm or corporation violating any of the provisions contained herein.

SECTION 9 - Any person violating any of the provisions of this Ordinance shall upon conviction thereof before any Justice of the Peace, be subject to a fine of five hundred dollars (\$500.00) for each and every offense, together with costs, and in default thereof, to imprisonment in the Allegheny County Jail for a period not to exceed thirty (30) days. Each failure to obtain a permit, to comply with any of the requirements of this Ordinance, and each and every day during which said violation shall continue, shall constitute a separate offense. In addition to the penalties so provided, the person or persons so violating the provisions of this Ordinance shall pay the cost of all highway repairs as hereinbefore provided.

SECTION 10 - Any ordinance or part of any ordinance which conflicts with the provisions of this ordinance shall be and the same is hereby repealed insofar as the same affects this Ordinance.

SECTION 11 - Should any section or provisions of this Ordinance be declared by a court of competent jurisdiction to be invalid, such decisions shall not affect the validity of this Ordinance as a whole or any part thereof, and parts or sections unaffected by the court decision shall remain in effect as though the part of section declared unconstitutional had not been a part thereof.

SECTION 12 - This Ordinance shall take effect immediately after final passage by the Township Commissioners and advertisement as required by law.

ORDAINED AND ENACTED into law this 3rd day of January, 1994.

ATTEST

KENNEDY TOWNSHIP

[Signature]  
Township Manager

by [Signature]  
President  
Board of Township Commissioners

Approved as to Form: [Signature]  
Township Solicitor

**TOWNSHIP OF KENNEDY**  
**ALLEGHENY COUNTY, PENNSYLVANIA**  
**ORDINANCE NO. 427**

**AN ORDINANCE OF THE TOWNSHIP OF KENNEDY, ALLEGHENY COUNTY, PENNSYLVANIA, AMENDING SECTION 5 OF ORDINANCE NO. 321, REGULATING THE GROUND OPENING OF STREETS AND RIGHT-OF-WAYS FOR THE USE OF THE PUBLIC.**

**WHEREAS**, the Kennedy Township Board of Commissioners find it necessary to adjust certain permit fees within the Township to maintain a fiscal balance to the administration of certain fees.

**NOW AND THEREFORE BE IT ORDAINED AND ENACTED** by the Board of Commissioners of the Township of Kennedy, Allegheny County, Pennsylvania, and it is hereby ordained and enacted by the authority of the same as follows:

**SECTION 1:** Section 5 of Ordinance No. 321 is amended to read as follows:

Each and every applicant shall pay to the Township the following permit fees at the time application is made for a permit to excavate or open any street or right-of-way in the Township. Where the excavation or opening is:

- |  |           |
|--|-----------|
| a. Less than 100 sq. ft.   | \$ 150.00 |
| b. 100 sq. ft. but less than 200 sq. ft.                             | \$ 225.00 |
| c. 200 sq. ft. but less than 300 sq. ft.                             | \$ 300.00 |
| d. 300 sq. ft. but less than 1,000 sq. ft.                           | \$ 650.00 |
| e. Each additional 300 sq. ft. or part thereof will be an additional | \$ 300.00 |

**SECTION 2:** All other Ordinances and Resolutions and/or parts of Ordinances or Resolutions conflicting with this Ordinance are hereby repealed.

**SECTION 3:** This Ordinance shall become effective and enacted the first day of January in the year 2006.

**ORDAINED AND ENACTED** by the Board of Commissioners of the Township of Kennedy this 12<sup>th</sup> day of December 2005.

**ATTEST:**

**TOWNSHIP OF KENNEDY**

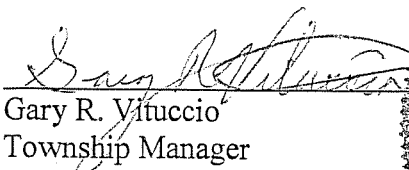
  
Gary R. Vituccio  
Township Manager

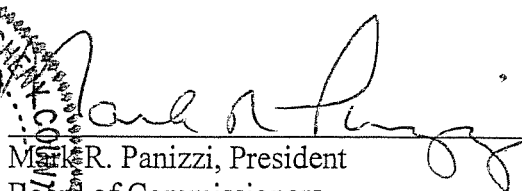

  
Mark R. Panizzi, President  
Board of Commissioners



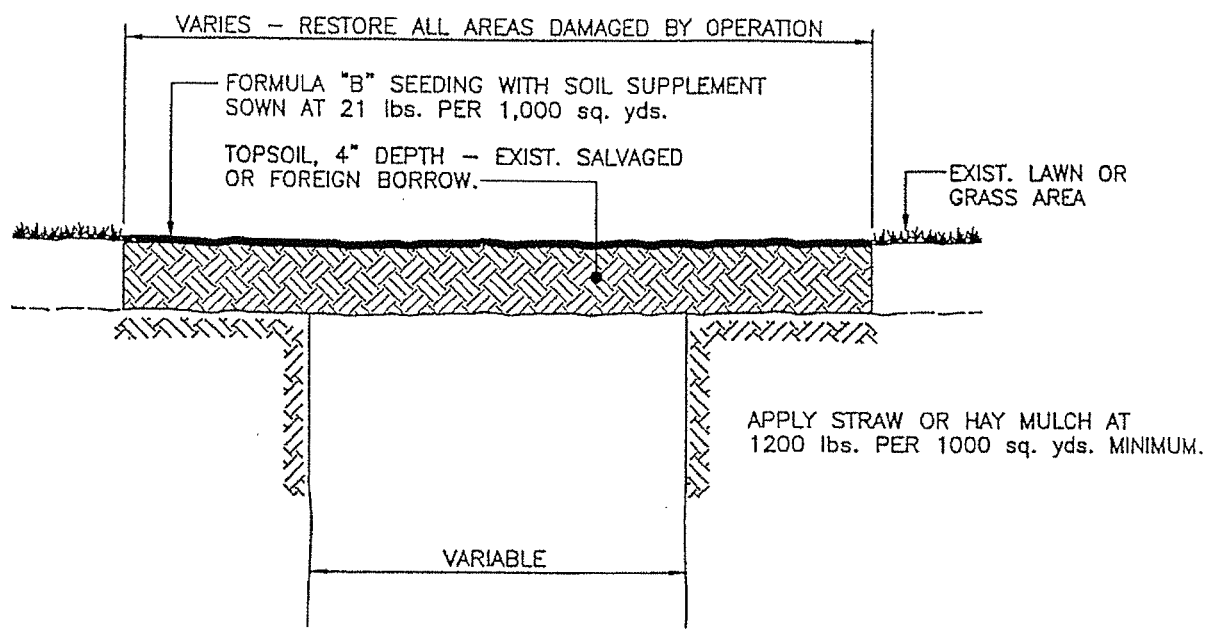

LAWN AND GRASS AREA  
RESTORATION DETAIL

EXISTING  
SLAG DRIVEWAY

TYPE 'A' No. 57 COARSE AGGREGATE  
PENNDOT SECT. 703.2 (NO SLAG)  
OR LIMESTONE CHIPS TO MATCH EXIST.,  
CHOKE AND ROLL, 4" MIN. DEPTH.

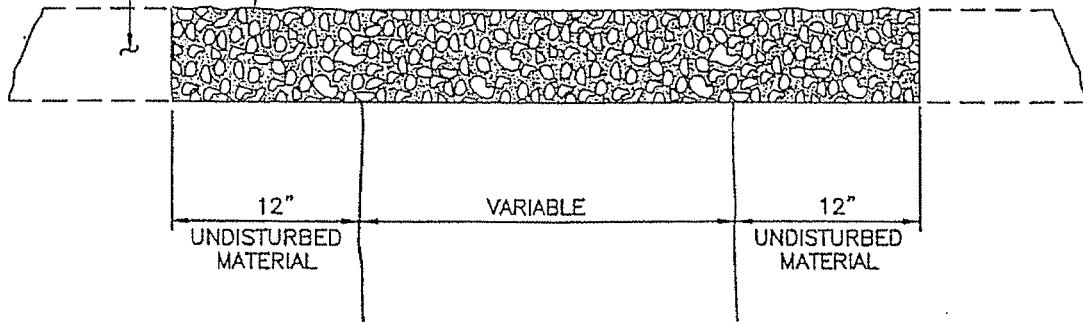

SLAG DRIVEWAY  
RESTORATION DETAIL

(APPLICABLE ONLY TO ROADS RESURFACED IN THE LAST FIVE (5) YEARS.)

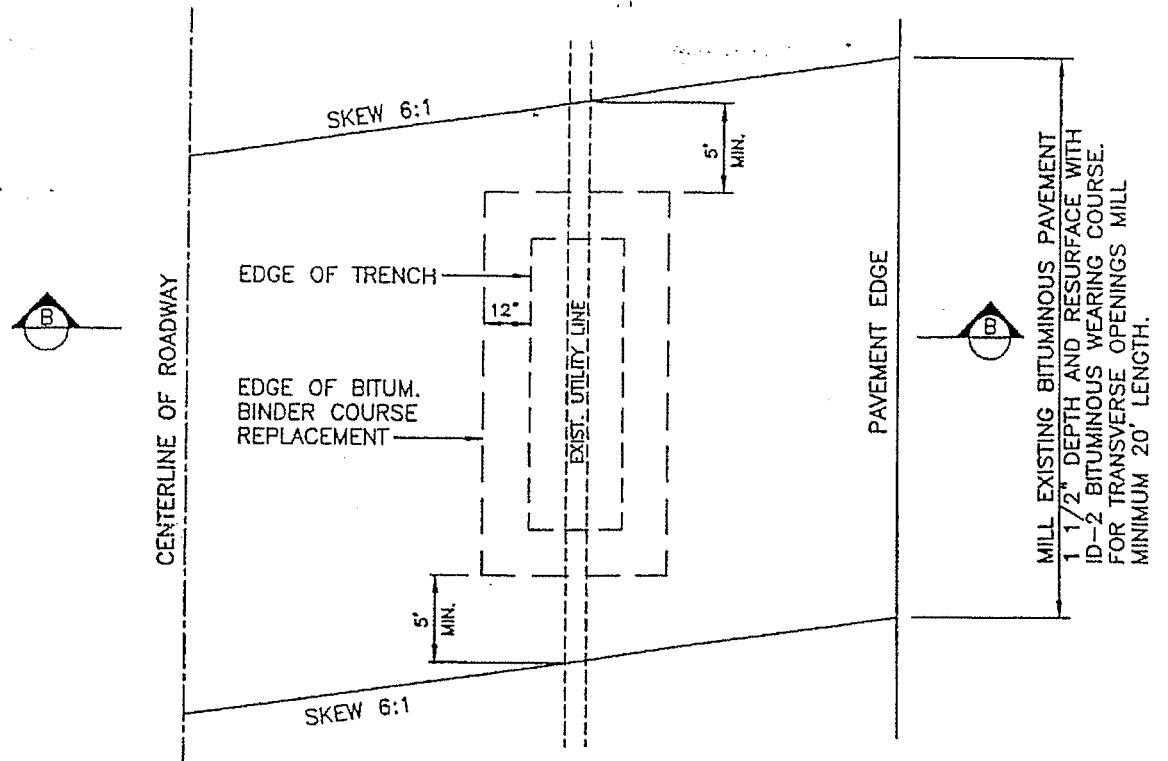

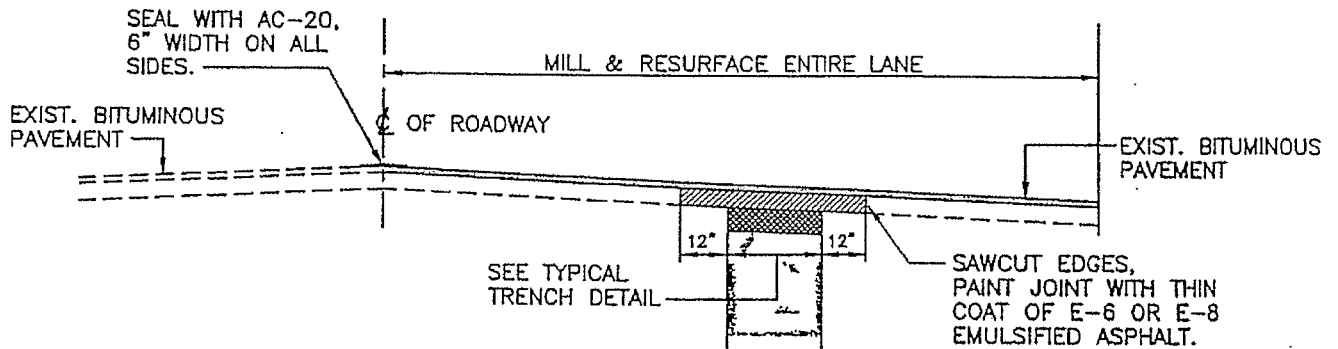

PLAN - PAVEMENT RESTORATION DETAIL 'B'



SECTION B-B

**NOTE:**

1. 2" MINIMUM BITUMINOUS COLD PATCH (TEMPORARY SURFACE) REQUIRED IN TRENCH AREA PRIOR TO FINAL SURFACING.
2. IF UTILITY OPENING EXTENDS INTO OR INVOLVES BOTH LANES THE ENTIRE CARTWAY SHALL BE MILLED AND RESURFACED.
3. THE MINIMUM LENGTH OF THE MILLED AND RESURFACED AREA SHALL BE 20 FEET.

-  1 1/2" ID-2 BITUMINOUS WEARING COURSE, PENNDOT SECT. 420
-  5" BITUMINOUS CONCRETE BASE COURSE, PENNDOT SECT. 305
-  6" No. 2A SUBBASE, PENNDOT SECT. 350

STANDARD BITUMINOUS  
PAVEMENT REPLACEMENT DETAIL

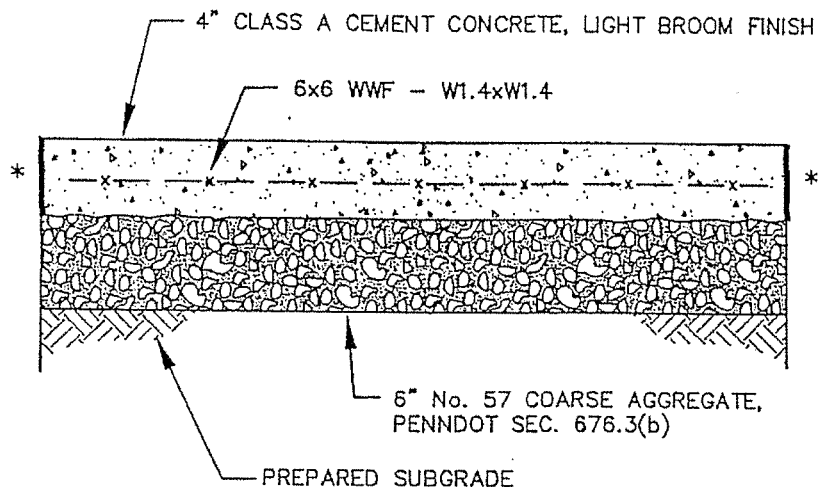

NOTES:

1. FORM OUTSIDE EDGES AND JOINTS WITH 1/4" RADIUS EDGING TOOL.
2. FORM TRANSVERSE DUMMY JOINTS @ 5 FOOT INTERVALS, APPROX. 1/8" WIDE AND AT LEAST 1 INCH DEEP.
- \*3. WHEN BUTTING INTO EXISTING BITUMINOUS, SAWCUT BITUMINOUS AND PAINT BITUMINOUS WITH A THIN COAT OF E-6 OR E-8 EMULSIFIED ASPHALT.
- \*4. WHEN BUTTING INTO EXISTING CONCRETE, SAWCUT CONCRETE AND USE 1/2" PREMOLDED EXPANSION FILLER FULL DEPTH OF SIDEWALK.

TYPICAL CONCRETE SIDEWALK  
REPLACEMENT DETAIL

(APPLICABLE ONLY TO ROADS NOT RESURFACED  
IN THE LAST FIVE (5) YEARS.)

SEAL WITH AC-20,  
6" WIDTH ON ALL  
SIDES.

SEAL JOINTS IN ACCORDANCE WITH PENNDOT  
SECT. 401.3(j)3, 6" BOTH SIDES OF JOINT  
WITH E-6 OR E-8 EMULSIFIED ASPHALT OR  
HOT BITUMINOUS MATERIAL

EXIST. BITUMINOUS  
SURFACE

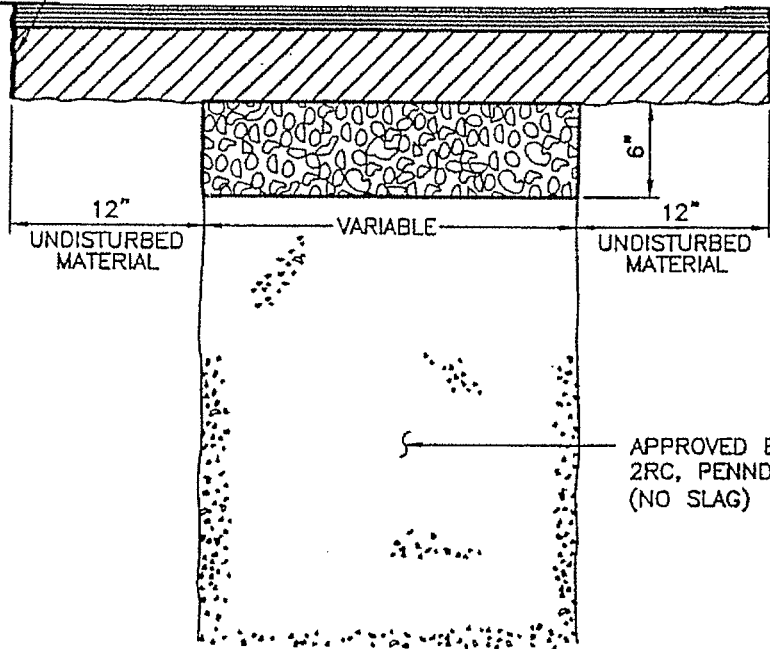

SAWCUT EDGES,  
PAINT JOINT WITH THIN  
COAT OF E-6 OR E-8  
EMULSIFIED ASPHALT.

12"  
UNDISTURBED  
MATERIAL

VARIABLE

12"  
UNDISTURBED  
MATERIAL

APPROVED EXCAVATED MATERIAL OR  
2RC, PENNDOT SECT. 703.3 AS DIRECTED  
(NO SLAG)

**NOTE:**

1. ALL BACKFILL SHALL BE COMPACTED IN 6" LAYERS,  
MECHANICALLY TAMPED.
2. TEMPORARY BITUMINOUS COLD PATCH SHALL BE USED IN ALL  
AREAS WHERE EXISTING FLEXIBLE-BASE PAVEMENT HAS BEEN  
REMOVED.

 1 1/2" ID-2 BITUMINOUS WEARING COURSE,  
PENNDOT SECT. 420

 5" BITUMINOUS CONCRETE BASE COURSE,  
PENNDOT SECT. 305

 6" No. 2A SUBBASE,  
PENNDOT SECT. 350

STANDARD TRENCH DETAIL  
AND PAVEMENT REPLACEMENT FOR  
BITUMINOUS PARKING AREAS, DRIVEWAYS,  
BERMS, AND TOWNSHIP ROADS